

mounting direction

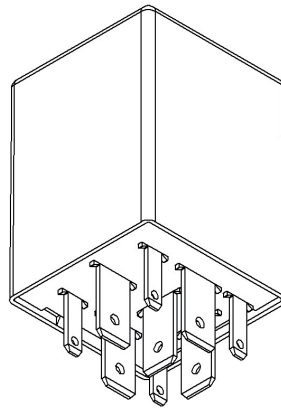

angled view

DESCRIPTION

The PROP CAN valve controller with CAN bus regulates the flow rate of a proportional valve. It can be used in many hydraulic applications. CAN high speed or CAN low speed, alternatively RS485, can be used to communicate with other modules and supports easy integration into existing systems.

TECHNICAL DATA

Housing	Plastic
Connector	9-pin base plate
Weight	60 g
Temperature range (acc. to ISO 16750-4)	-40 °C to + 85 °C
Environmental protection	IP 6K8, when watertight socket is used and the mounting direction is correct
Current consumption	30 mA
Over-current protection	1 A + Laststrom
Total Inputs and outputs	3 Analog inputs, 1 PWM output
Input	Analog input 0... 11.4 V
Output	PWM output
Operating voltage	9 - 32 V (Code C for 12 V, Code E for 24 V)
Overtoltage protection	≥ 33 V
Quiescent current	integrated
CAN interface	CAN Interface 2.0 A/B ISO 11898-2 compliant

REGULATORY APPROVALS AND TESTING

E1 approval	05 7521
Elektical tests	Acc. to. ISO 16750: Short circuit protection Reverse polarity protection Interruption pin Interruption plug Long-term overvoltage at $T_{65^{\circ}\text{C}}$ Storage test T_{max} and T_{min} Operation test T_{max} and T_{min} Temperature steps Wet heat Superimposed alternating voltage Reset behaviour during voltage drop Acc. to. ISO 7637 - 2: Puls 1, 2a, 2b, 3a, 3b, 4 Acc. to. ISO 10605: ESD up to ± 8 kV

SOFTWARE/PROGRAMMING

Programming System	MRS Developers Studio MRS Developers Studio MRS Developers Studio with built-in functions library, similar programming with FUP. Custom software blocks can be integrated into "C-code". Program memory is sufficient for about 300 basic logic components. For extended storage capacity from 32k you need the Codewarrior license. Download the paid license easily and securely from NXP.
--------------------	--

INPUT FEATURES - SUMMARY

Pin 1 (X) Pin 4 (15)	Usable as analog or digital input		Pin 3 (C)	Usable as analog or digital input	
	Resolution	12 Bit		Resolution	12 Bit
	Accuracy	1% Full scale		Accuracy	1% Full scale
Voltage input 0...11.4 V (see A)	Input resistance	22.7 kΩ	Voltage input 0...11.4 V (see B)	Input resistance	22.7 kΩ
	Input frequency	$f_c^1 = 60$ Hz		Input frequency	$f_c^1 = 60$ Hz
	Accuracy	± 3 %		Accuracy	± 3 %
Digital input positive (see A)	Input resistance	22.7 kΩ	Digital input positive (see B)	Input resistance	22.7 kΩ
	Input frequency	$f_g^1 = 60$ Hz		Input frequency	$f_g^1 = 60$ Hz
	Turn-on threshold	6.5 V		Turn-on threshold	6.5 V
	Turn-off threshold	4.8 V		Turn-off threshold	4.8 V

¹ cutoff frequency (-3 dB)

OUTPUT FEATURES - SUMMARY

Pin 8 (87)	Protective circuit for inductive loads		Pin 3 (C) As open collector output	max. power (at T_{room})	2 W
	Recovery diode integrated				
	Wire fault diagnostics	Possible via current sense			
	Short circuit diagnostics	Possible via current sense			
PWM output (see C)	Output frequency	100 Hz- 5 kHz			
	Switching current (Limiting continuous current)	3 A			
	Valve connection:	Pin 8 against Pin 5 (GND)			

PIN ASSIGNMENT POWER SUPPLY AND INTERFACES

Pin	Description	Pin	Description
2	Operating voltage	7	CAN high
6	Ground	9	CAN low

PIN ASSIGNMENT IN- AND OUTPUTS

Pin	Signal	Description	Pin	Signal	Description
1	ANA_X D_ANA_X	Analog input X 0-11.4 V or digital input	5	-	Connection proportional valve negative (B)
3	ANA_C D_ANA_C C	Analog input C 0-11.4 V or digital input C or Digital output (open collector, 2 W max.)	8	ANA_PWM	Connection proportional valve positive (A),
4	ANA_15 D_ANA_15	Analog input 15 0-11.4 V or digital input 15	-	ANA_POTI	Analog input of internal potentiometer; 0-4095 digits

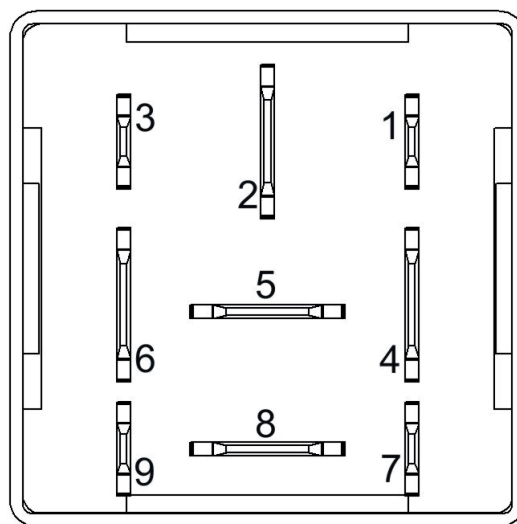

view of plug - bottom view

PIN FEATURE MAP

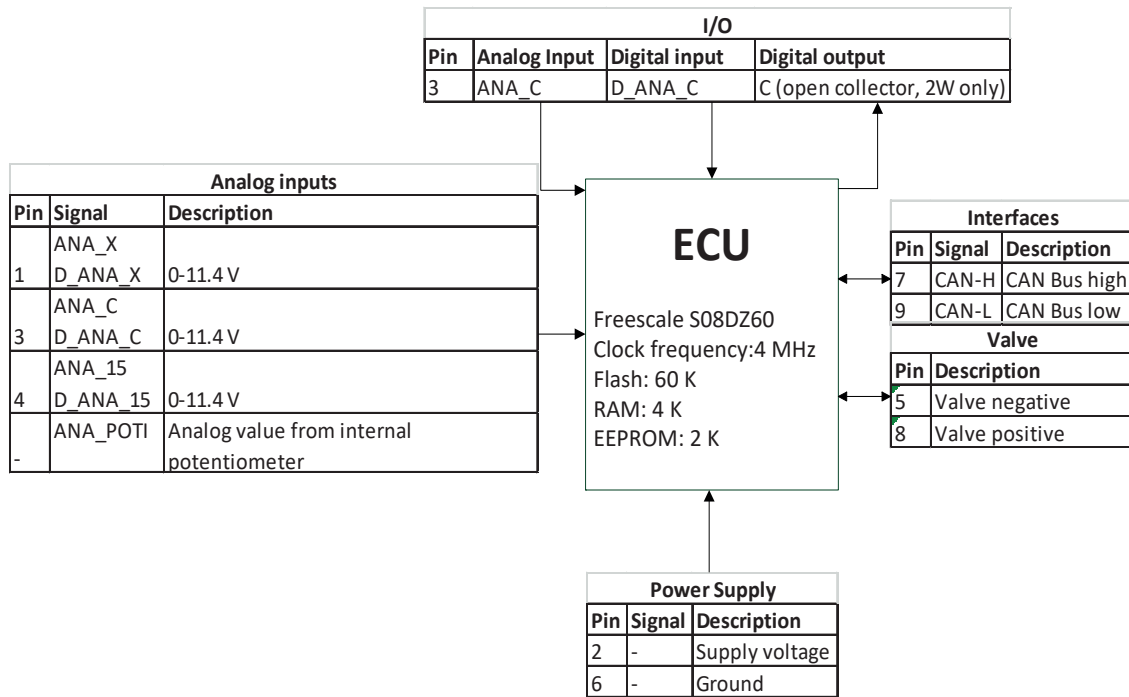

BLOCK DIAGRAM

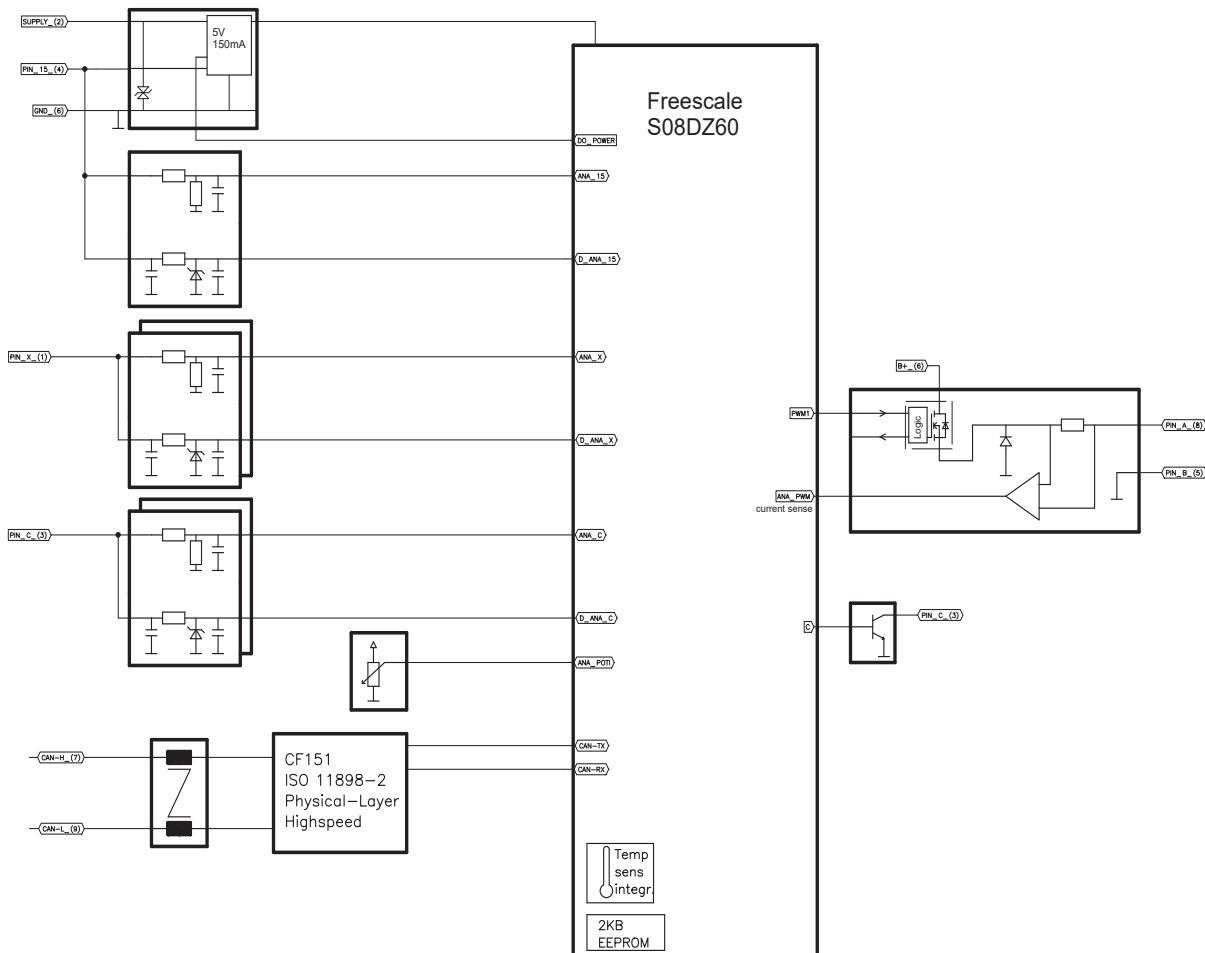

TECHNICAL DRAWING IN MM [IN INCH]

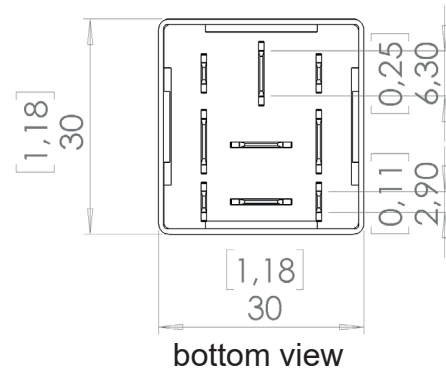
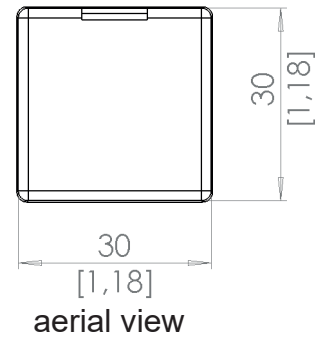
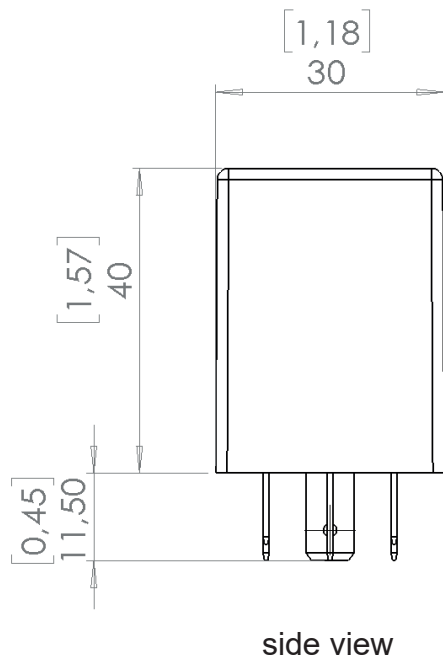

ASSEMBLY VARIANTS AND ORDERING INFORMATIONS

	Pins inputs		Outputs		CAN bus	Remarks
	A voltage 0 – 11.4 V	B I/O's (optionally as analog input or digital output)	C PWM (100 Hz - 5 kHz)	High-Speed		
1.108.310.00	1, 4	3	8 → 5	X		The output of the controller for the proportional valve (pin 8 and 5) may only be operated with the load connected. The maximum connection length from control output to valve is 2m. If this length must be exceeded for application reasons, an individual acceptance test must be carried out.
1.108P.310.00	1, 4	3	8 → 5	X		CANopen variant The output of the controller for the proportional valve (pin 8 and 5) may only be operated with the load connected. The maximum connection length from control output to valve is 2m. If this length must be exceeded for application reasons, an individual acceptance test must be carried out.
1.108.310.1A	1, 4	3	8 → 5	X		Ground: PIN 5 (valve negative) and PIN 6 (Ground) bridged The output of the controller for the proportional valve (pin 8 and 5) may only be operated with the load connected. The maximum connection length from control output to valve is 2m. If this length must be exceeded for application reasons, an individual acceptance test must be carried out.

ACCESSORIES

Description	Order number
Programming tool MRS Developers Studio	1.100.100.09
Cable set Prop CAN	109446
Socket	1.017.002.00
Socket package watertight 40 mm	114265
Tab receptacle 6,3 mm 1,5 – 2,5 mm ²	103064
Tab receptacle 6,3 mm 1 mm ²	102355
Tab receptacle 2,8 mm 0,5 – 1,0 mm ²	105292
PCAN USB interface	105358

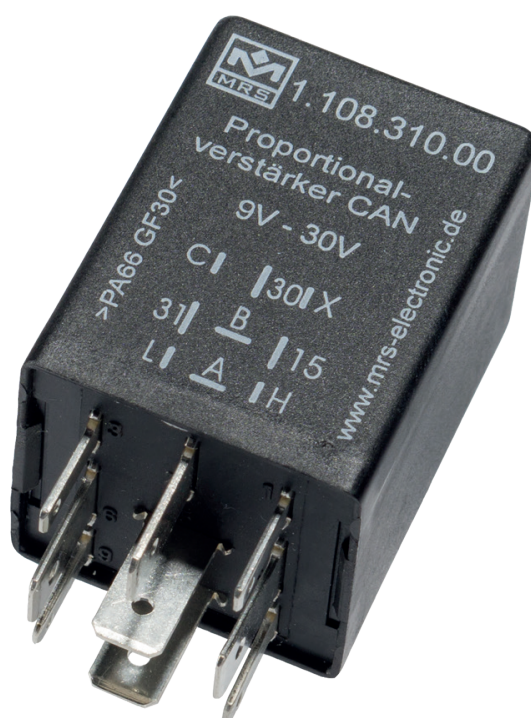

MANUFACTURER

MRS Electronic GmbH & Co. KG
 Klaus-Gutsch-Str. 7
 78628 Rottweil
 Germany

NOTES ON WIRING AND CABLE ROUTING

CAN bus communication is the main communication between the control unit and the vehicle. Therefore, connect the CAN bus with special care and check the correct communication with the vehicle to avoid undesired behavior.

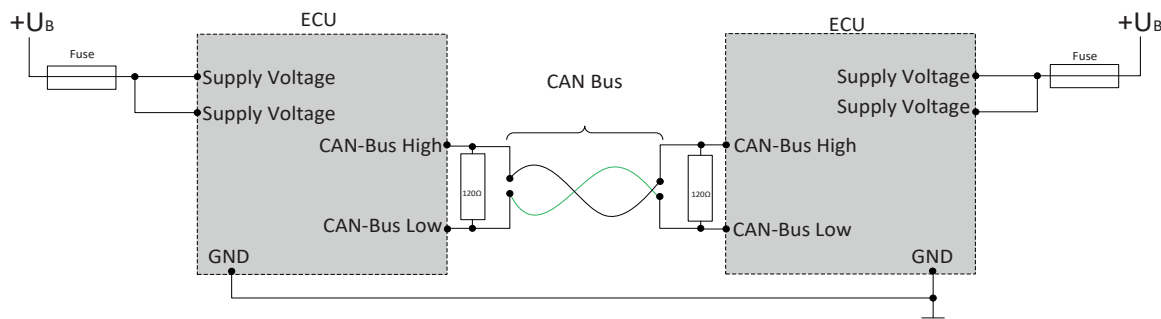

The open-collector output may only be switched to power supply of the module.

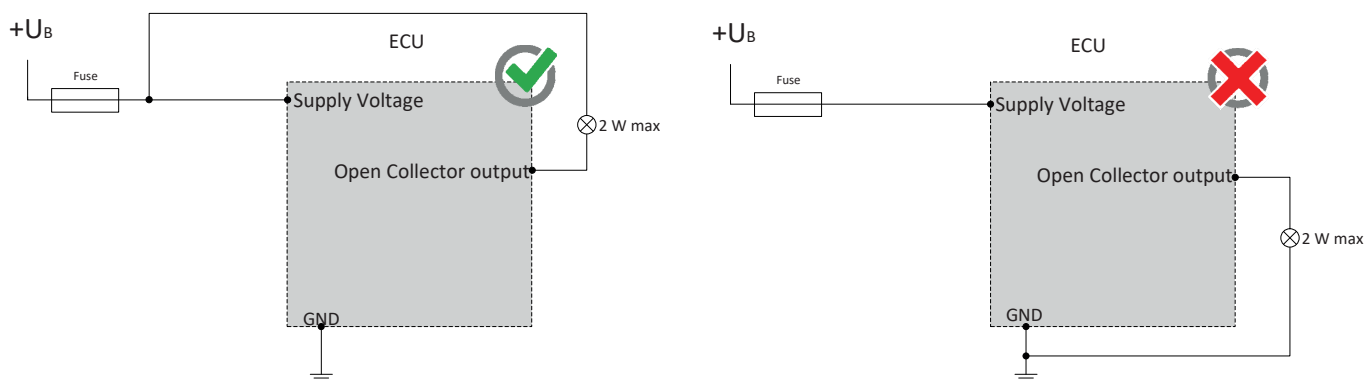

The output of the valve (pin 8 and 5) may only operate with connected load between pin 8 and 5. The length between ECU and valve may not exceed 2 m. If this length must be exceeded for application, an individual acceptance must take place.

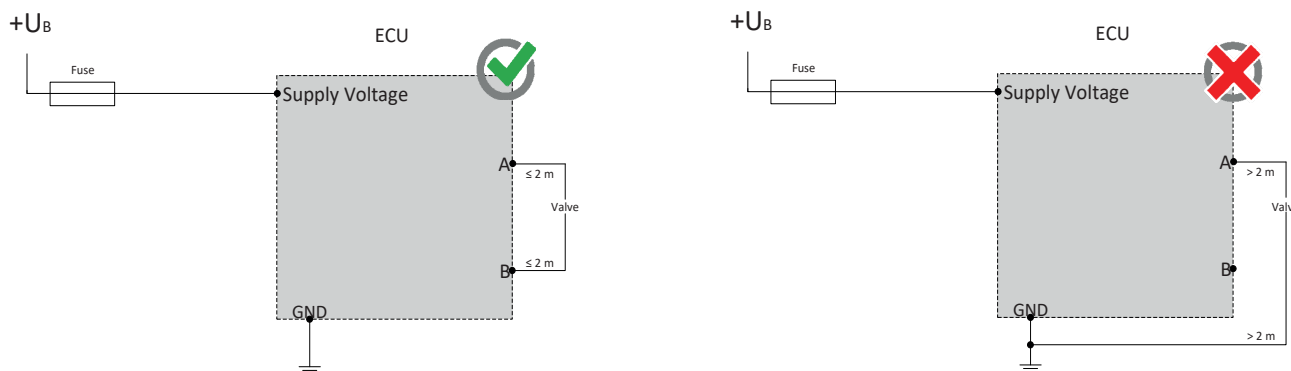

SAFETY AND INSTALLATION INFORMATION

It is essential to read the instructions in full thoroughly before working with the device.

Please note and comply with the instructions in the operating instructions and the information in the device data sheet, see www.mrs-electronic.de

Staff qualification: Only staff with the appropriate qualifications may work on this device or in its proximity.

SAFETY

-
- ⚠ WARNING! Danger as a result of a malfunction of the entire system.**
 Unforeseen reactions or malfunctions of the entire system may jeopardise the safety of people or the machine.
- Ensure that the device is equipped with the correct software and that the wiring and settings on the hardware are appropriate.
-

- ⚠ WARNING! Danger as a result of unprotected moving components.**
 Unforeseen dangers may occur from the entire system when putting the device into operation and maintaining it.
- Switch the entire system off before carrying out any work and prevent it from unintentionally switching back on.
 - Before putting the device into operation, ensure that the entire system and parts of the system are safe.
 - The device should never be connected or separated under load or voltage.
-

- ⚠ CAUTION! Risk of burns from the housing.**
 The temperature of the device housing may be elevated.
- Do not touch the housing and let all system components cool before working on the system.
-

PROPER USE

The device is used to control or switch one or more electrical systems or sub-systems in motor vehicles and machines and may only be used for this purpose. The device may only be used in an industrial setting.

- ⚠ WARNING! Danger caused by incorrect use.**
 The device is only intended for use in motor vehicles and machines.
- Use in safety-related system parts for personal protection is not permitted.
 - Do not use the device in areas where there is a risk of explosion.
-

Correct use:

- operating the device within the operating areas specified and approved in the associated data sheet.
- strict compliance with these instructions and no other actions which may jeopardise the safety of individuals or the functionality of the device.

Obligations of the manufacturer of entire systems

It is necessary to ensure that only functional devices are used. If devices fail or malfunction, they must be replaced immediately.

System developments, installation and the putting into operation of electrical systems may only be carried out by trained and experienced staff who are sufficiently familiar with the handling of the components used and the entire system.

It is necessary to ensure that the wiring and programming of the device does not lead to safety-related malfunctions of the entire system in the event of a failure or a malfunction. System behaviour of this type can lead to a danger to life or high levels of material damage.

The manufacturer of the entire system is responsible for the correct connection of the entire periphery (e.g. cable cross sections, correct selection/connection of sensors/actuators).

Opening the device, making changes to the device and carrying out repairs are all prohibited. Changes or repairs made to the cabling can lead to dangerous malfunctions. Repairs may only be carried out by MRS.

Installation

The installation location must be selected so the device is exposed to as low a mechanical and thermal load as possible. The device may not be exposed to any chemical loads.

Install the device in such a manner that the plugs point downwards. This means condensation can flow off the device. Single seals on the cables/leads must be used to ensure that no water gets into the device.

Putting into operation

The device may only be put into operation by qualified staff. This may only occur when the status of the entire system corresponds to the applicable guidelines and regulations.

FAULT CORRECTION AND MAINTENANCE

- i NOTE The device is maintenance-free and may not be opened.**
- If the device has damage to the housing, latches, seals or flat plugs, it must be taken out of operation.

Fault correction and cleaning work may only be carried out with the power turned off. Remove the device to correct faults and to clean it.

Check the integrity of the housing and all flat plugs, connections and pins for mechanical damage, damage caused by overheating, insulation damage and corrosion. In the event of faulty switching, check the software, switches and settings.

Do not clean the device with high pressure cleaners or steam jets. Do not use aggressive solvents or abrasive substances.